

Ignition lances

Connection to ignition devices for the ignition of gas or liquid fuels in industrial burners of any capacity.

Features

- Ignition tip temperature-proof up to 600°C, up to 800°C for a short period
- High-temperature model temperature-proof up to 1000°C.

Applications

- Chemical industry
- Refineries
- Cement plants
- Waste incinerators
- Steam generators
- Heating plants
- Claus plants.

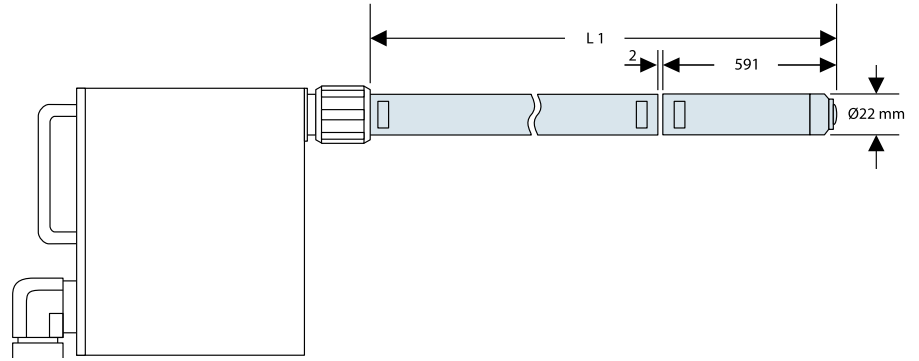

Ignition lance for D-HG 400-50, -51

Lance length L1	min. 0.7 m, max. 15 m	Weight	1.6 kg/m at Ø22 mm
-----------------	-----------------------	--------	--------------------

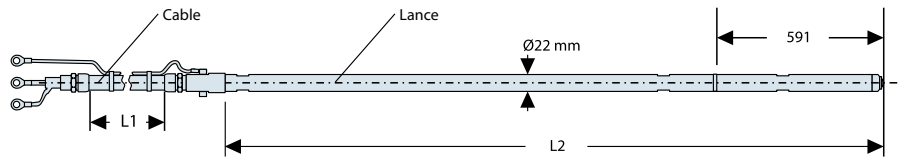

D-ZL 411 CG: separated ignition lance connectable to D-HG 400-53 Ex / -72 Ex or customer device

Cable length L1	min. 1 m, max. 50 m	Cable weight	0,5 kg + 0,5 kg/m
Cable off-take angle at the lance	0° or 90°	Lance weight	1.6 kg/m at Ø22 mm
Lance length L2	min. 0.7 m, max. 15 m		

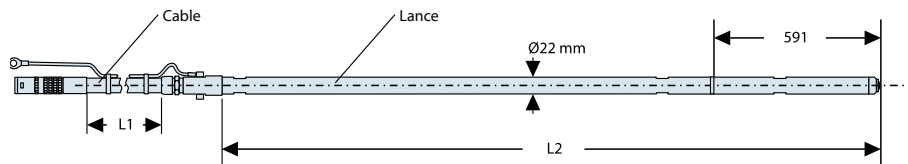

D-ZL 421: separated ignition lance for D-HG 400-65

Cable off-take at the device	0° or 90°	Lance length L2	min. 0,7 m, max. 15 m
Cable length L1	min. 1 m, max. 50 m	Cable weight	0.5 kg + 0.5 kg/m
Cable off-take at the lance	0° or 90°	Lance weight	1,6 kg/m at Ø22 mm

Special designs

- **D-ZL 422**
As D-ZL 421 but with handles for lance
- **D-ZL 423**
As D-ZL 421 but with lance plug-in connector
- **D-ZL 430/431**
As D-ZL 421 but with lance outlet box, for Ex-range Class I, Div. 1/2.

ATHEX Industrial Suppliers
www.athex.eu - info@athex.eu
 Tel: +32 (0)3 653 21 82